

SENATOR WOOD 400

cattelan
italia

design Paolo Cattelan - 2024



ISTRUZIONI DI MONTAGGIO - ASSEMBLING INSTRUCTIONS - MONTAGEANLEITUNG
INSTRUCTIONS DE MONTAGE - INSTRUCCIONES DE MONTAJE
ИНСТРУКЦИИ ПО МОНТАЖУ - 安装指导 - تعليمات التجميع

IT Cattelan Italia spa si riserva di apportare, senza preavviso, modifiche nei materiali, nei rivestimenti, nelle finiture e nei disegni dei prodotti. Le textures ed i colori dei materiali e delle finiture hanno valore indicativo in quanto soggetti alle tolleranze dei processi di stampa.

Riporre per eventuali consultazioni future.

EN Cattelan Italia spa reserves the right to change, without previous notice, materials, covers, finishes and drawings of the products. The textures and colours of materials and finishes are indicative as they are depending on the tolerances of the printing process.

File for future consultation.

DE Cattelan Italia spa behält sich vor, ohne Vorankündigung, Veränderungen an den Materialien, Bezügen, Finish und Zeichnungen Produkte vorzunehmen. Die Texturen und Farben der Materialien und Finish haben einen hinweisenden Wert, da sie von den Toleranzen im Druckprozess abhängig sind.

Bitte aufbewahren für eventuelle spätere Nachfragen.

FR Cattelan Italia spa se réserve le droit d'apporter, sans préavis, des modification au niveau des matériaux, des revêtements, des finitions et du design des produits. Les textures et les couleurs des matériaux et des finitions sont une valeurs indicative parce-que ils changent selon la tolérance aux procédés d'imprimerie.

A conserver pour les futurs besoins de reference.

ES Cattelan Italia spa se reserva el derecho de aportar modificaciones de dibujo, materiales, acabados y tapicerias, sin que esté obligada a dar aviso antipado. Las textures y los colores de los materiales y de los acabados tienen solo un valor indicativo porque estan sujetos a la tolerancia en los procesos de imprenta.

Guardar para consultas posteriores.

RU Cattelan Italia spa оставляет за собой право делать изменения, без предупреждения, в материалах, обивках, отделках и в чертежах продуктов, которые представлены в данном каталоге. Текстуры и цвета материалов и отделок в каталоге не передают реальные цвета предметов, из-за особенности процессов печати и цветопередачи.

Сохранить для возможной будущей консультации.

CN Cattelan Italia

公司保留变更图册中材料、包覆材质、饰面、图像的权利，无须事先通知。因印刷等工艺存在偏差，材料和饰面等的纹理和颜色仅供参考。

重要事项：存档以备日后咨询

AR تحتفظ شركة Cattelan Italia SPA بالحق في تغيير المواد والأغطية والتشطيبات والرسومات الخاصة بالمنتجات دون إشعار مسبق.

تعتبر قوام وألوان المواد والتشطيبات إرشادية لأنها تعتمد على تفاوتات عملية الطباعة.

هام: ملف للتشاور في المستقبل.



HARDWARE

n° 08 TCCE M8x25 N.

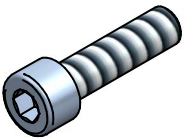

n° 12 TPSCE M8x40 N.

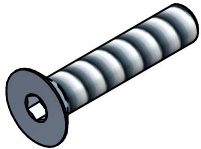

n° 12 TBCE M8x20 N.



n° 40 ø8x24 N.

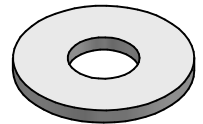

n° 20 medio M8 N.

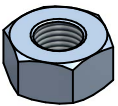

n° 16 ø10x50.

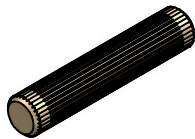

n° 07 pz.

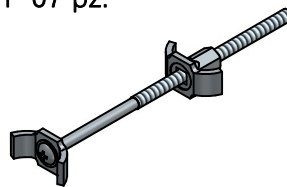

n° 06 pz.

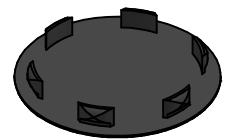

n° 03 pz 113 mm.



n° 10 feltro 8x50 sp.1,5 N.

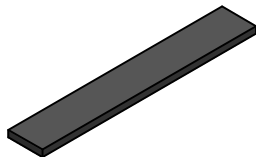

n° 08 feltro 750x25 N.

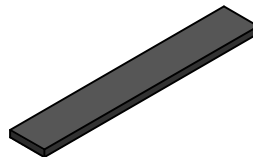

05 mm

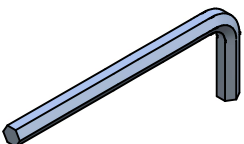

06 mm

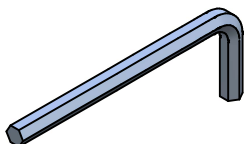

10

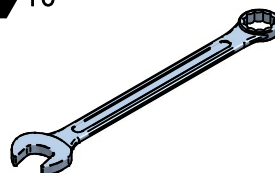

13

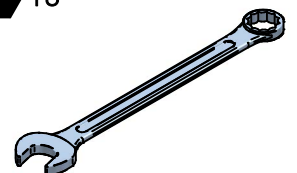

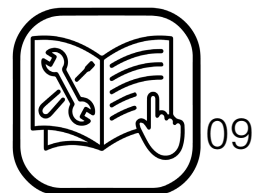
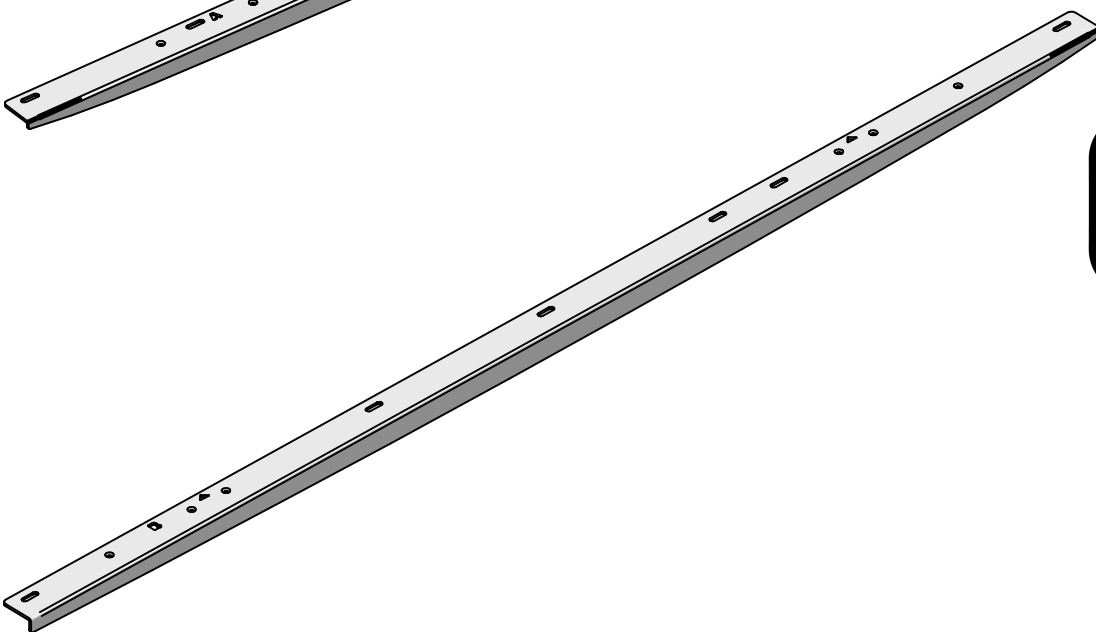
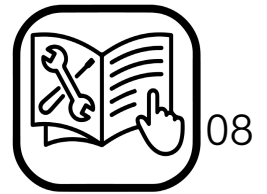
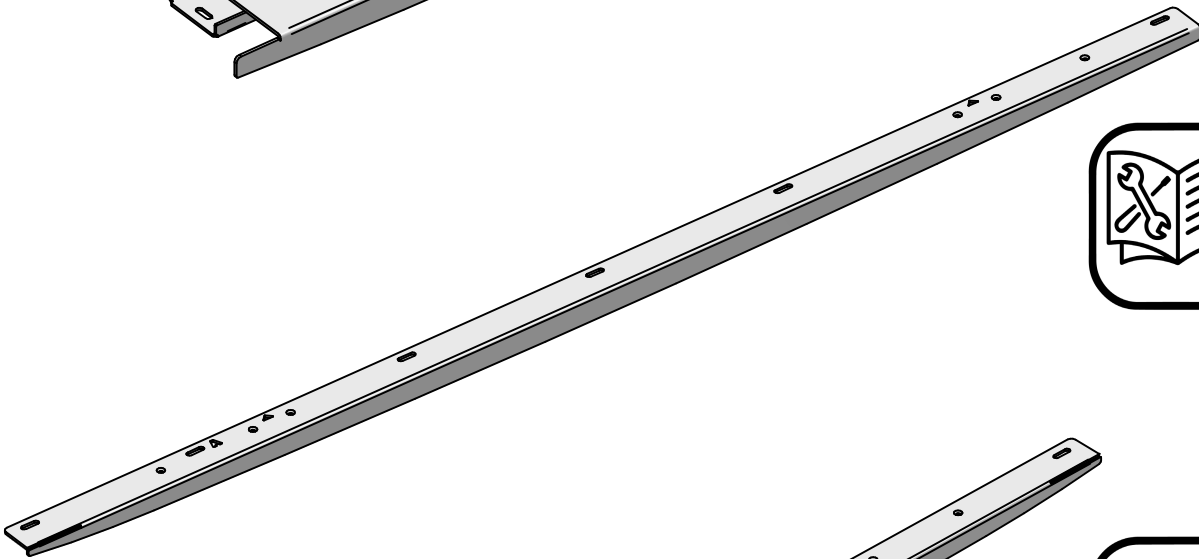
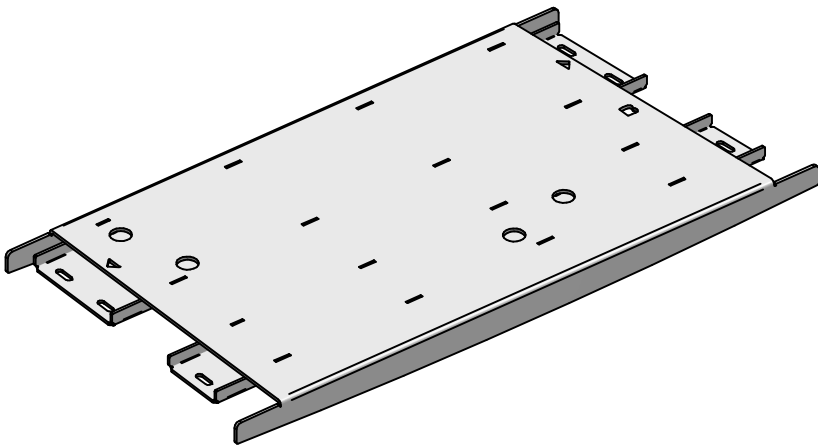
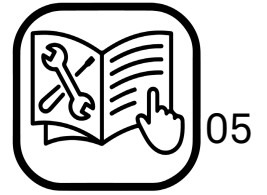
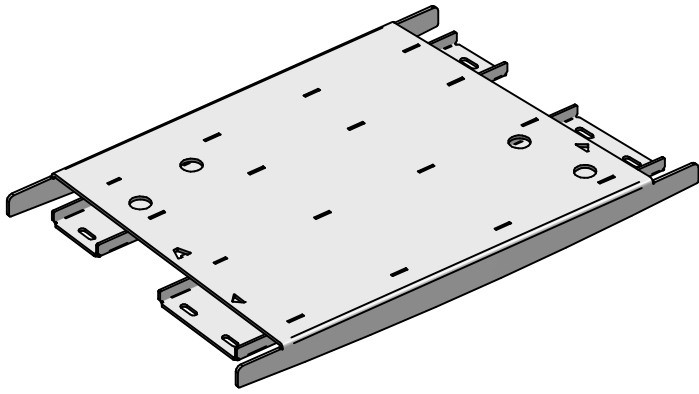

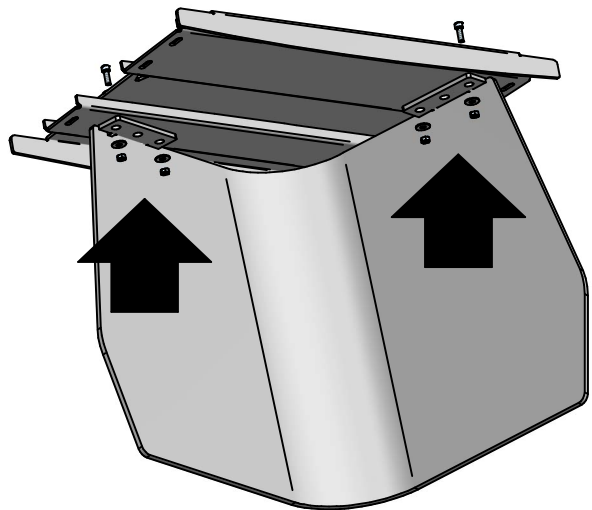
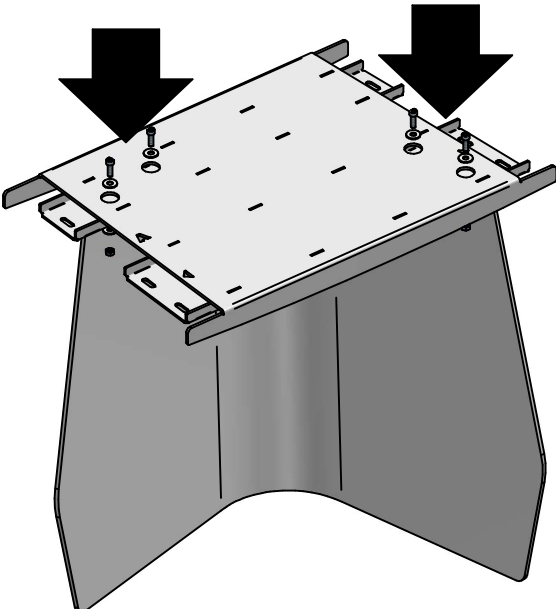
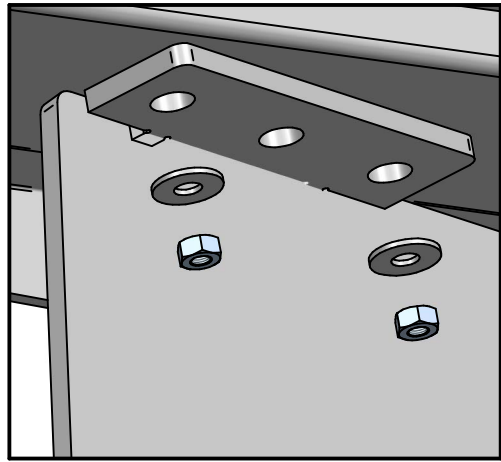
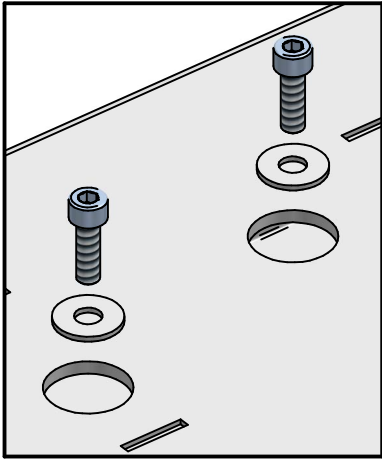
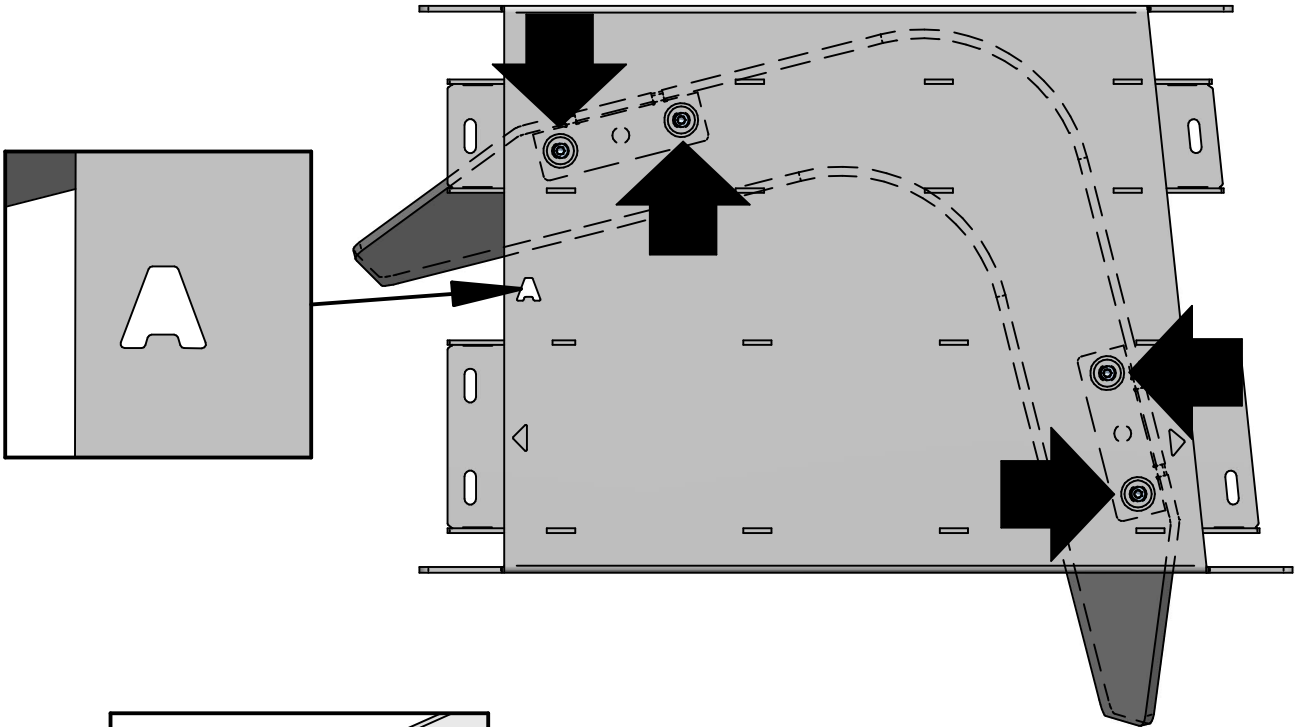
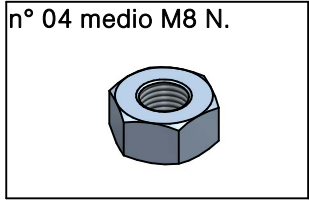
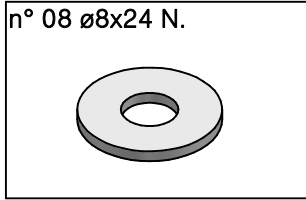
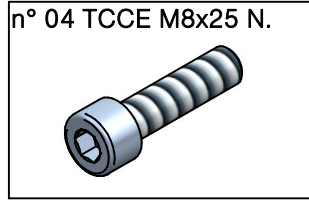

n° 04 TCCE M8x25 N.

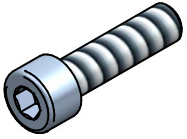

n° 08 ø8x24 N.

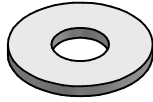

n° 04 medio M8 N.

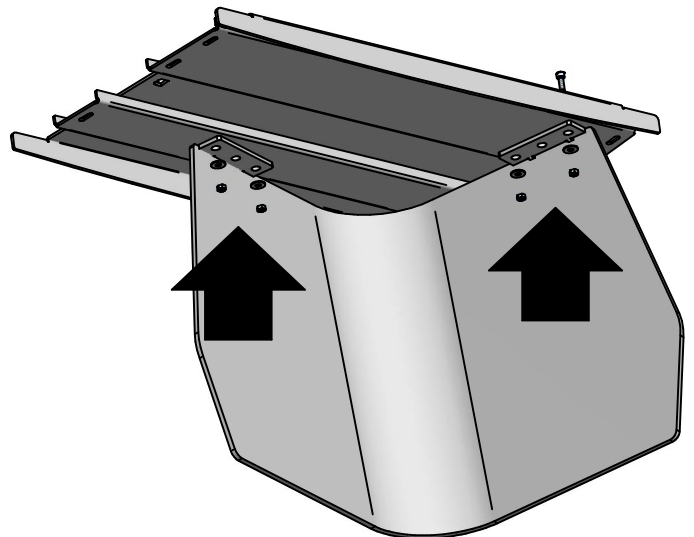
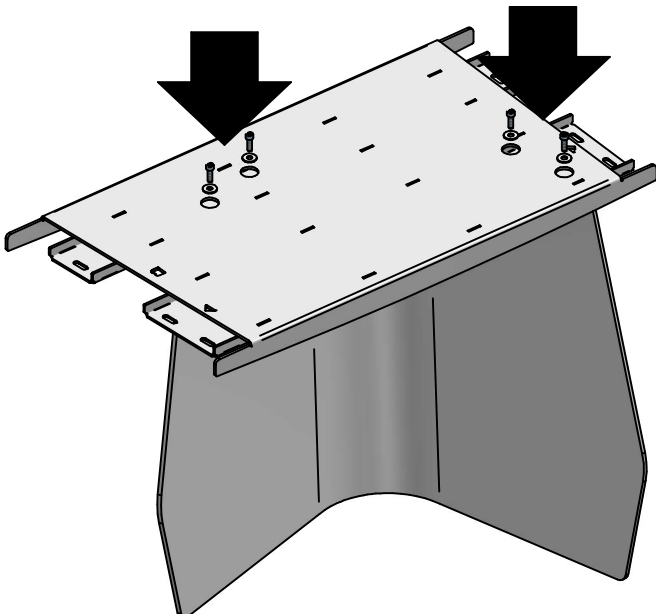
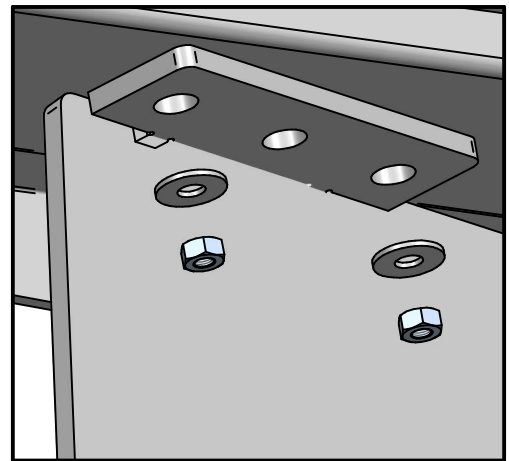
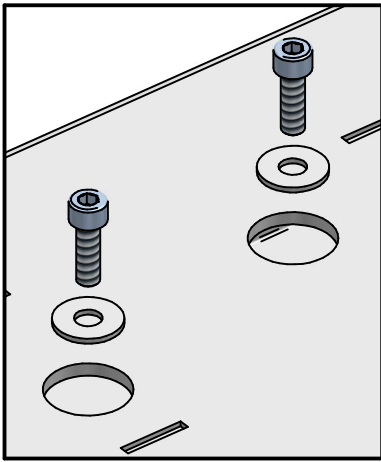
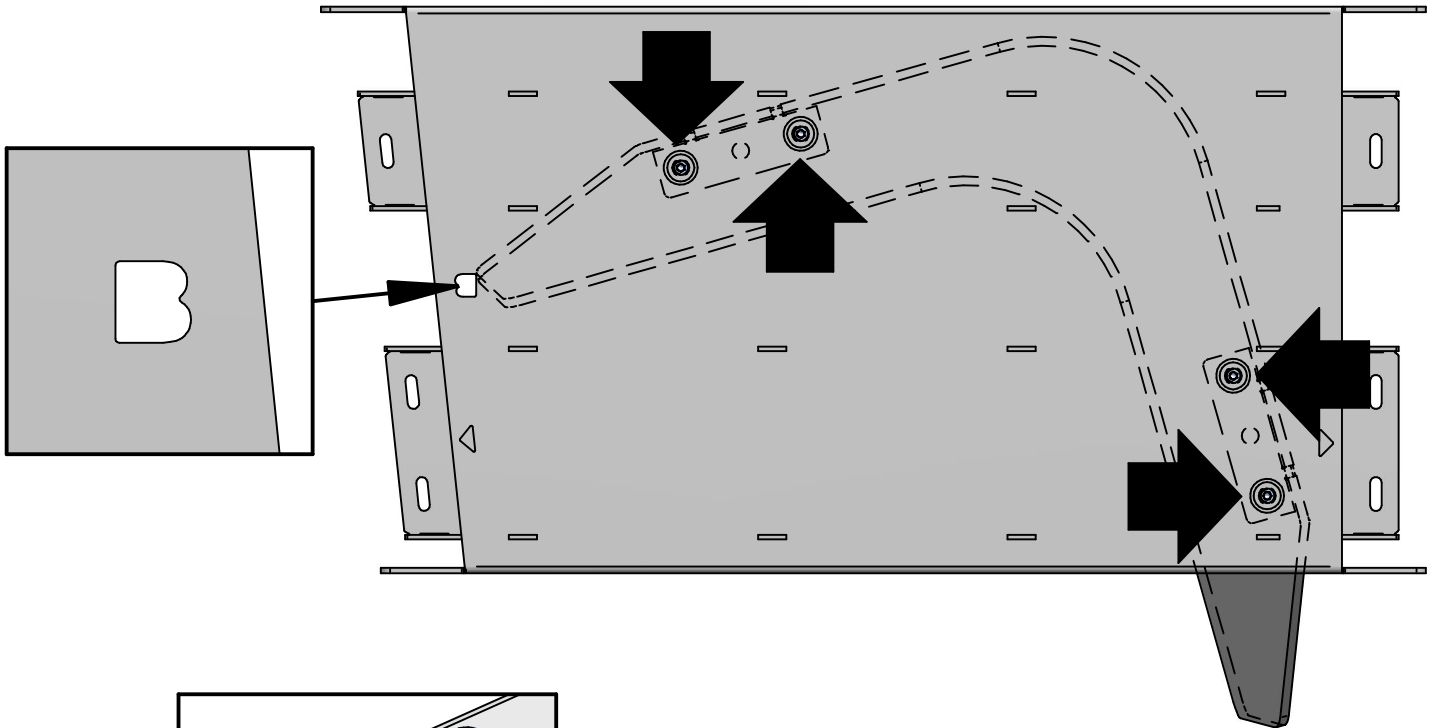
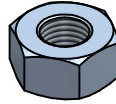

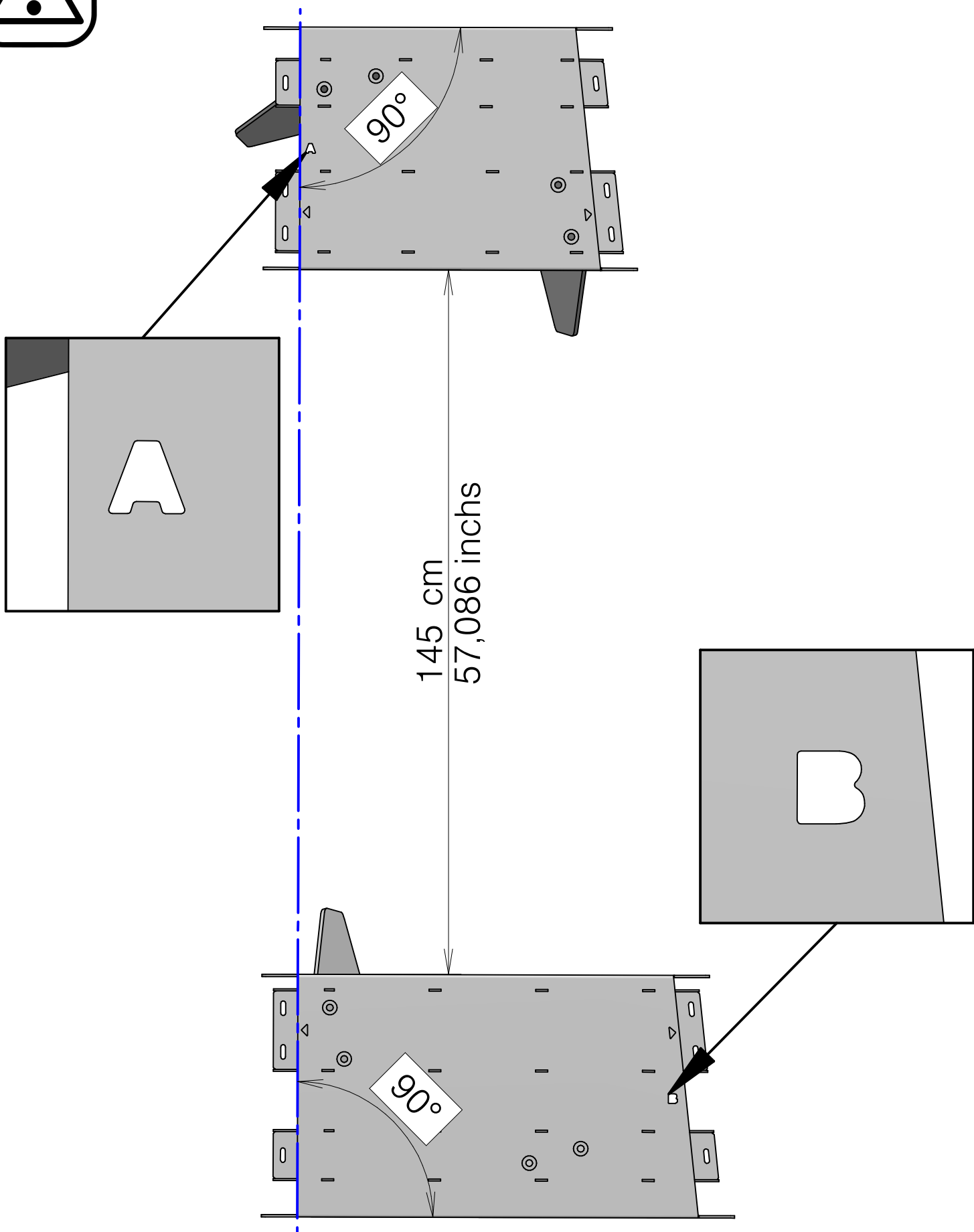

n° 06 TPSCE M8x40 N.

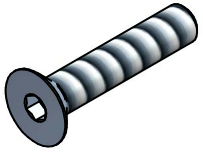

n° 06 ø8x24 N.

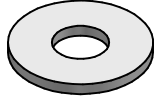

n° 06 medio M8 N.

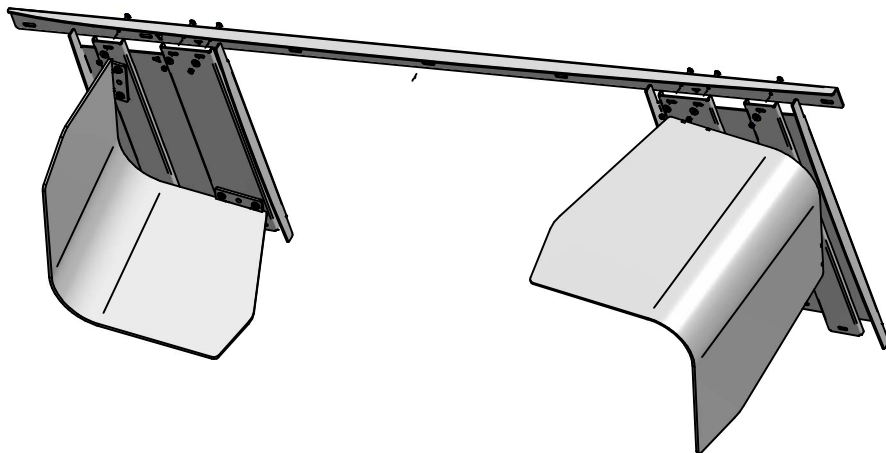
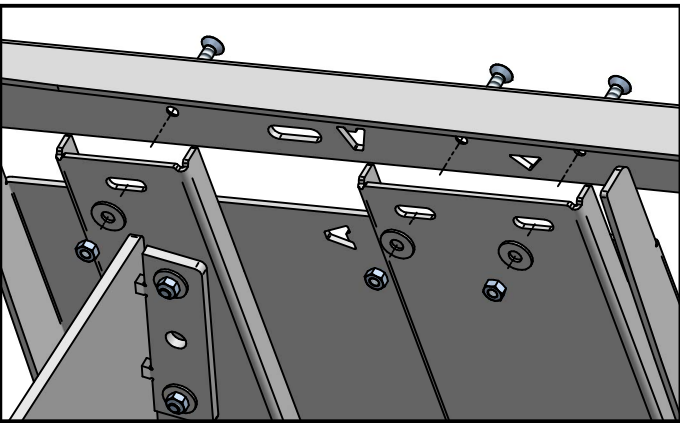
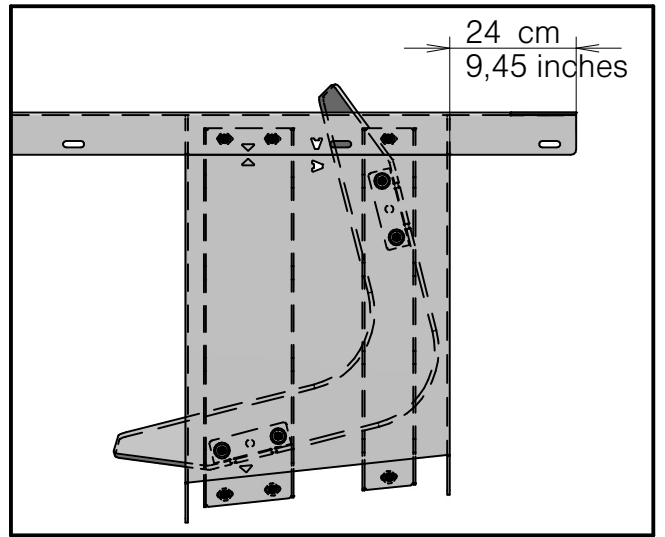
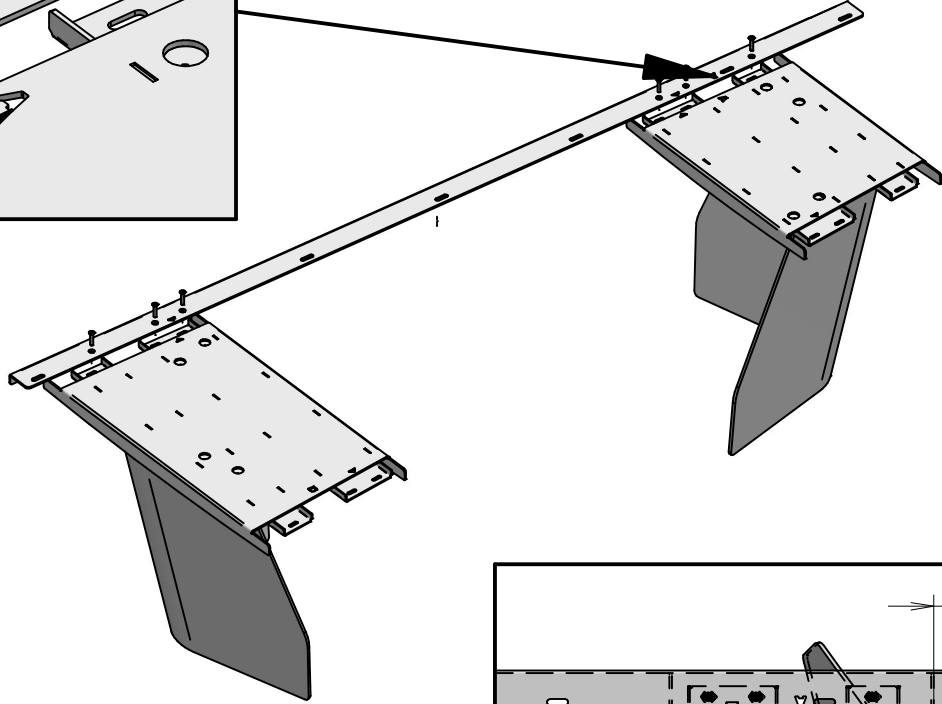
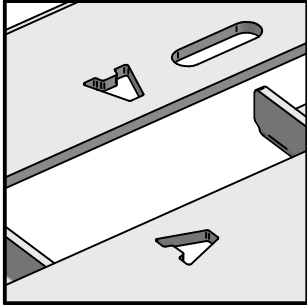
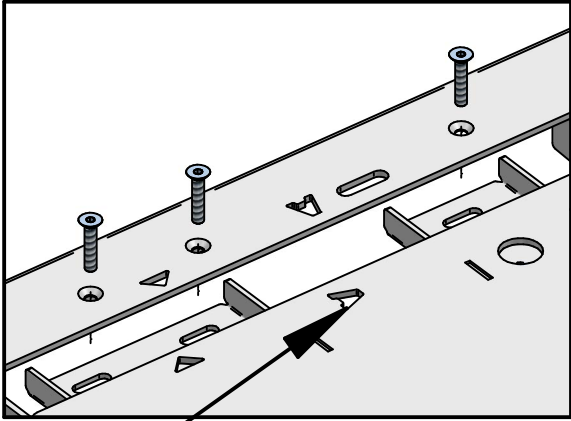

n° 06 TPSCE M8x40 N.

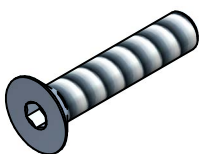

n° 06 ø8x24 N.

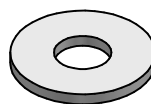

n° 06 medio M8 N.

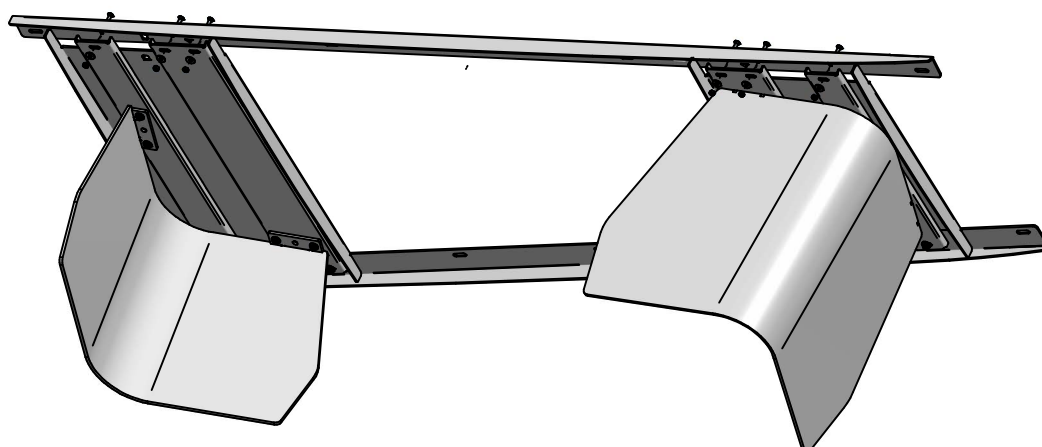
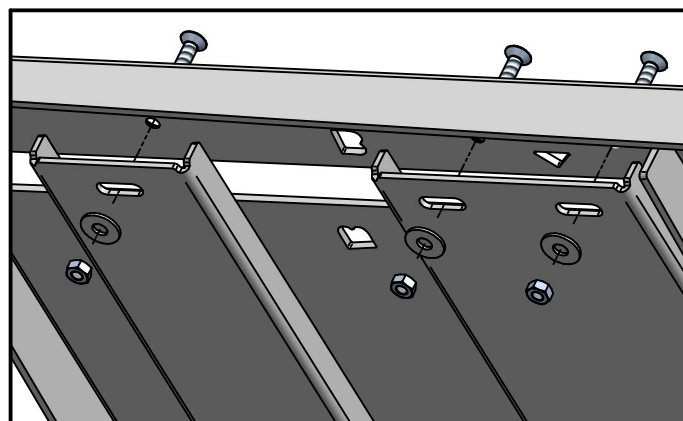
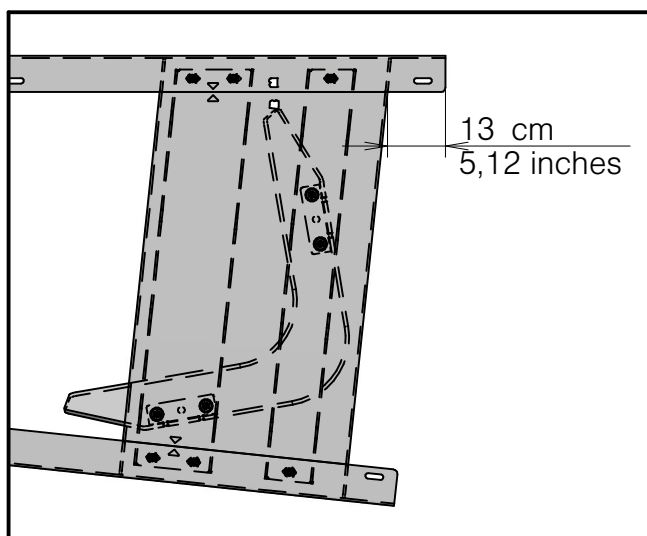
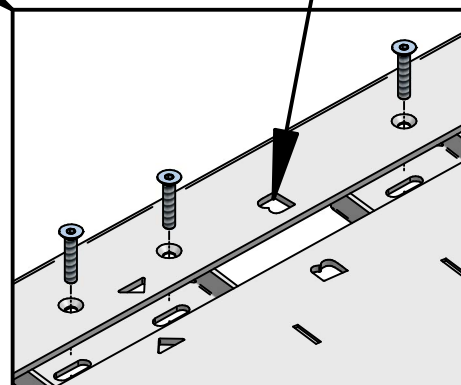
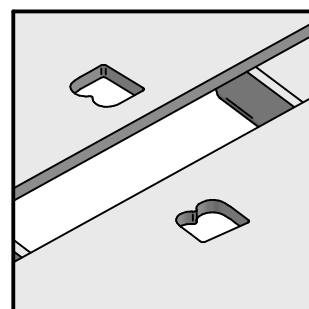
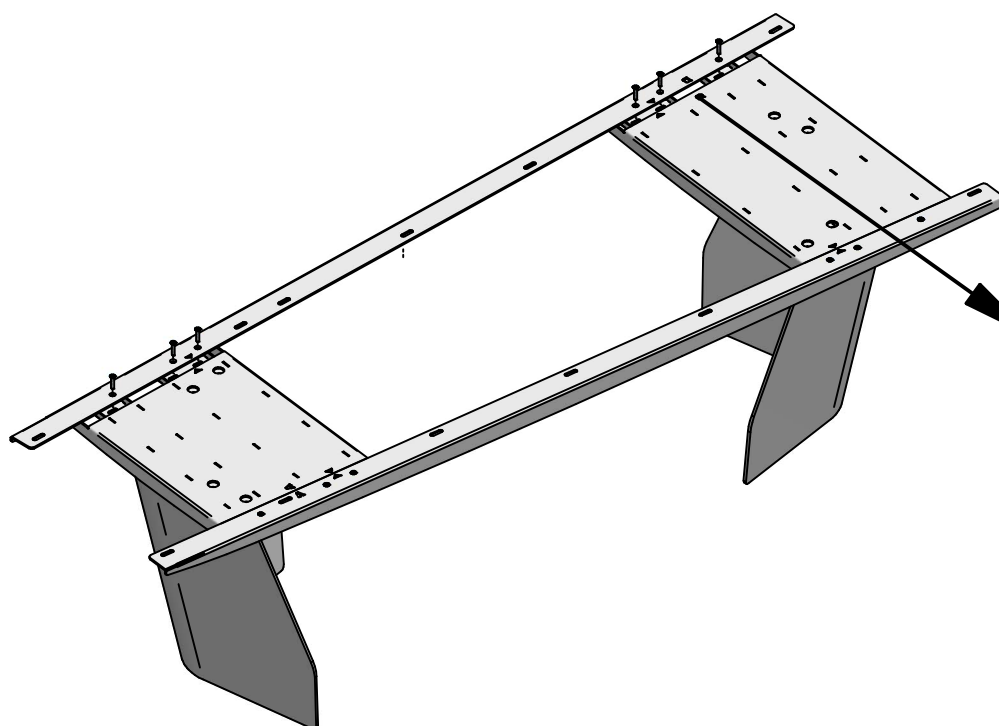
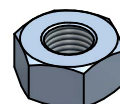

n° 08 feltro 750x25 nero.

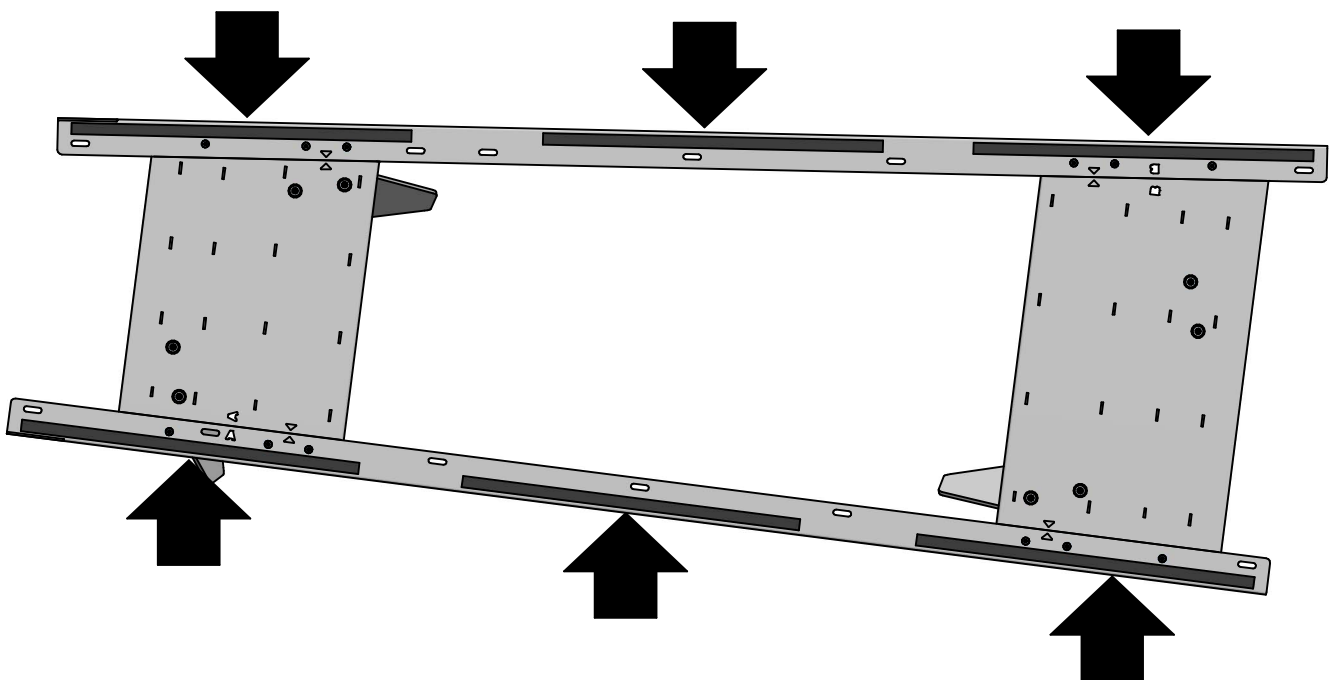
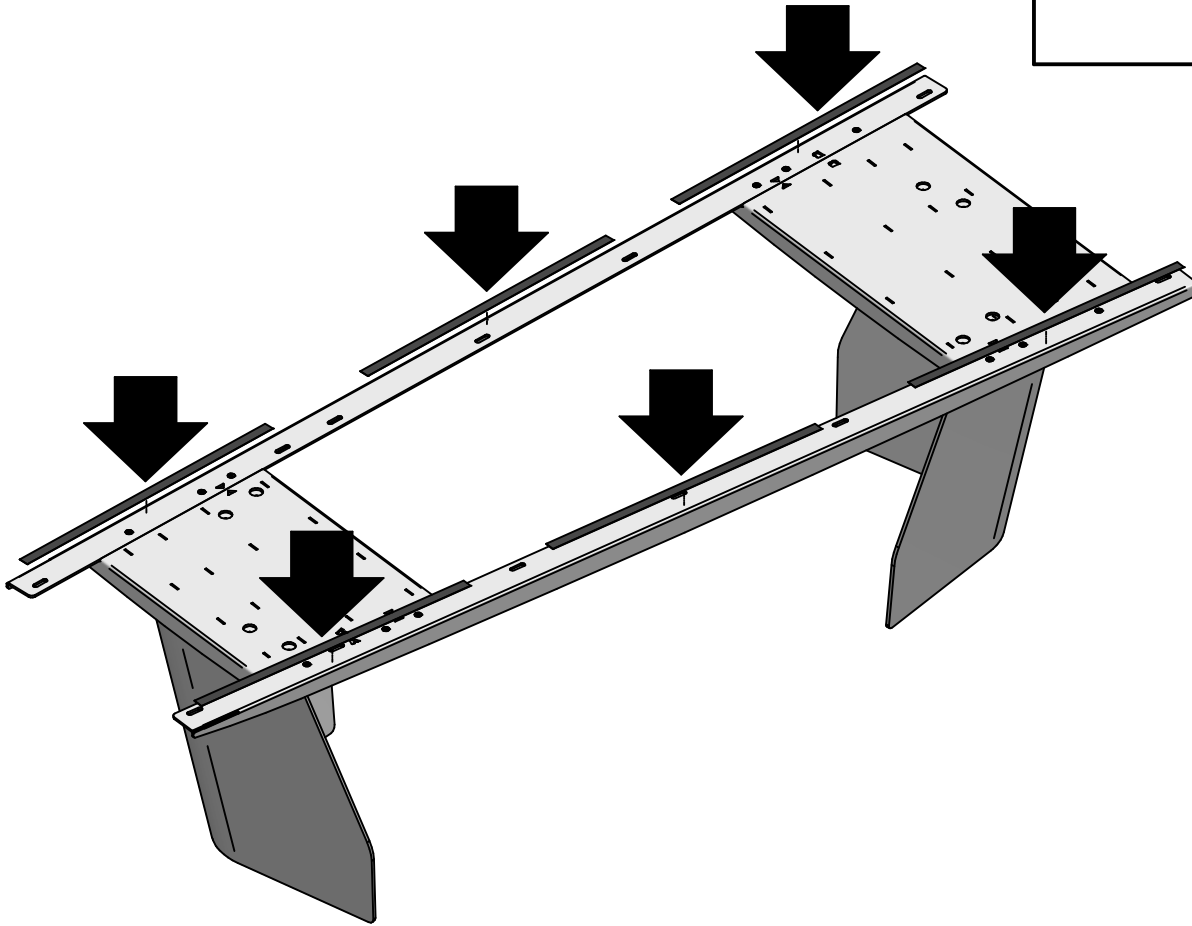
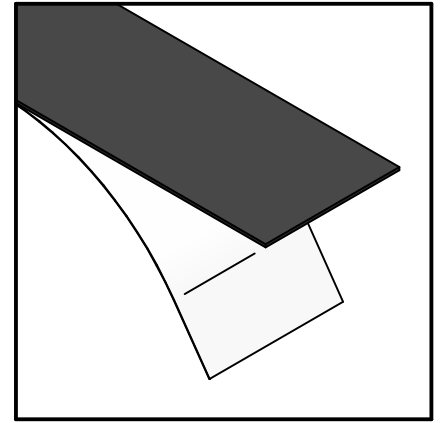
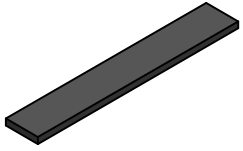

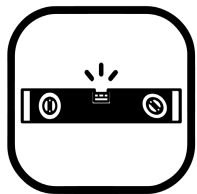

n° 10 feltro 8x50 sp.1,5 N.

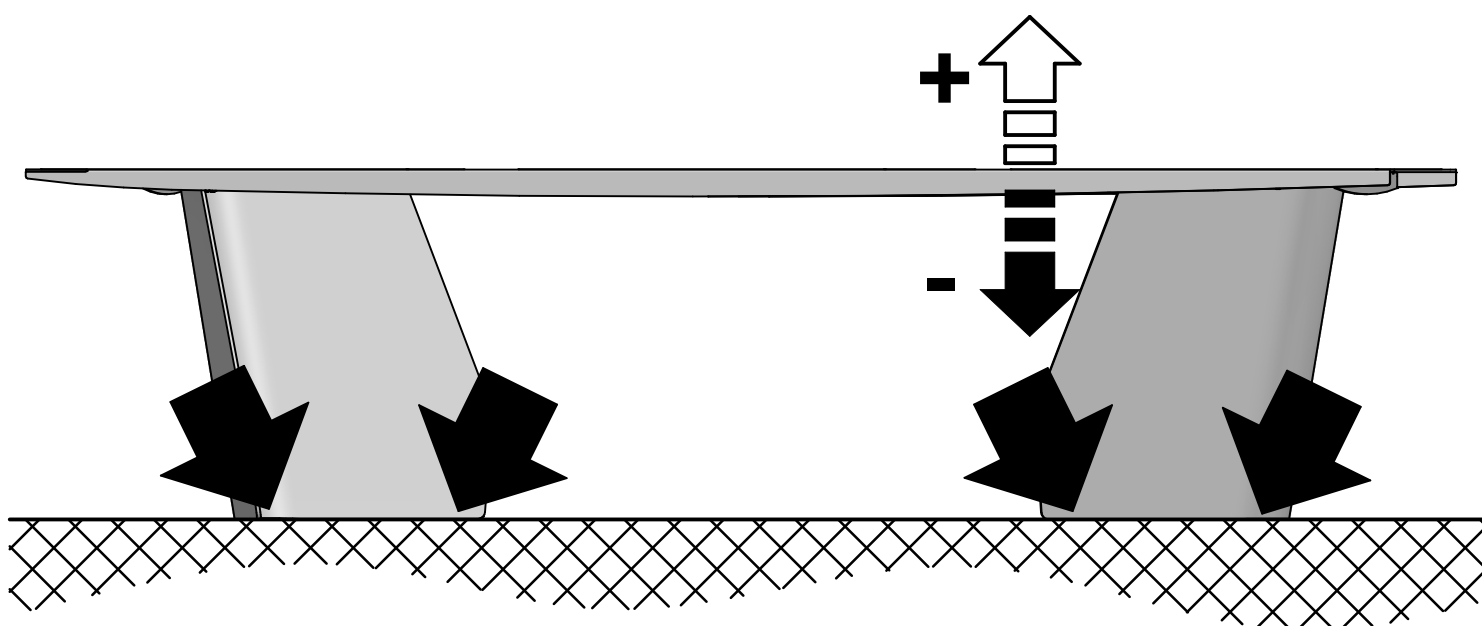
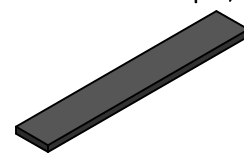

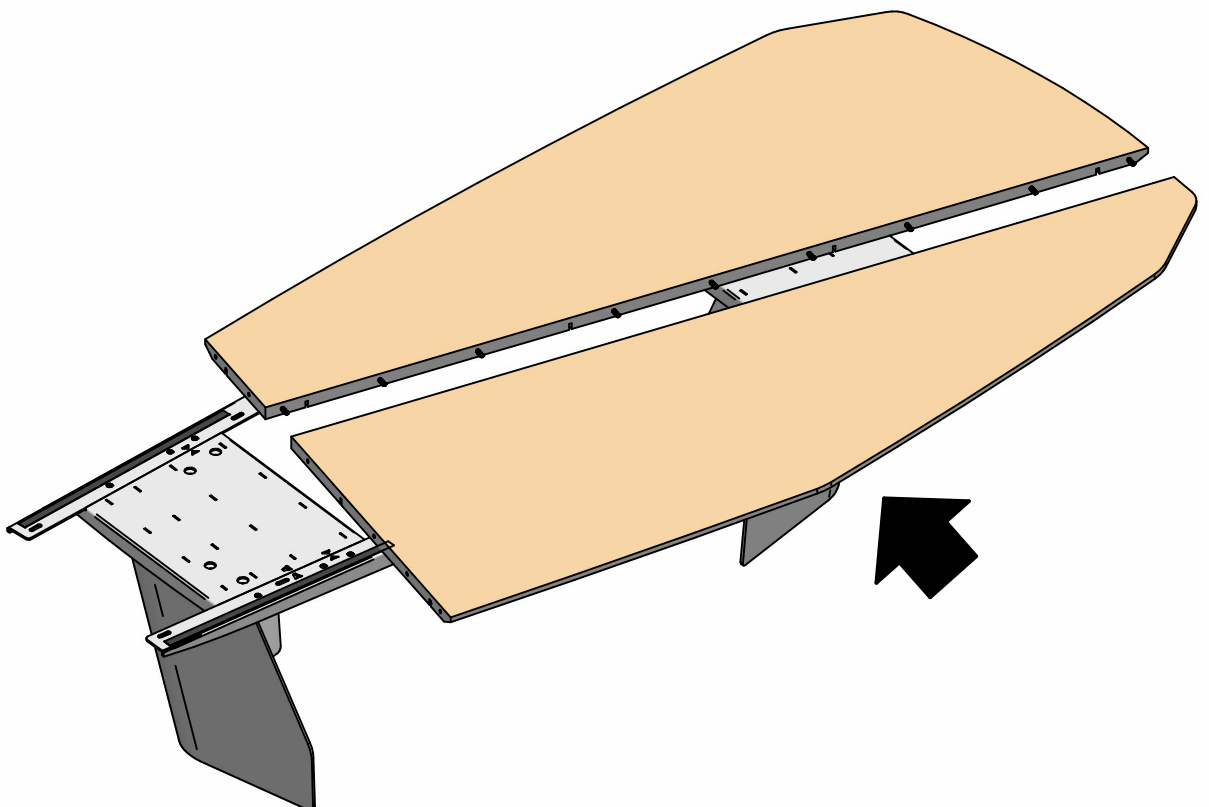
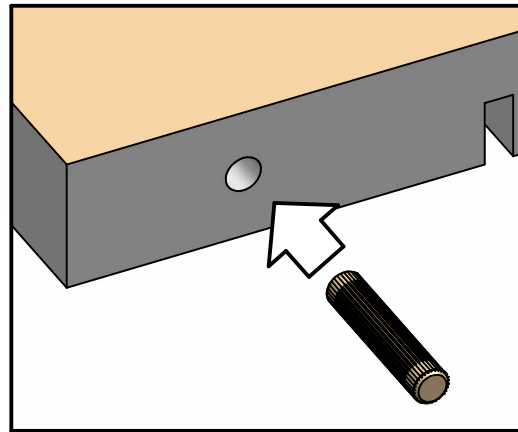
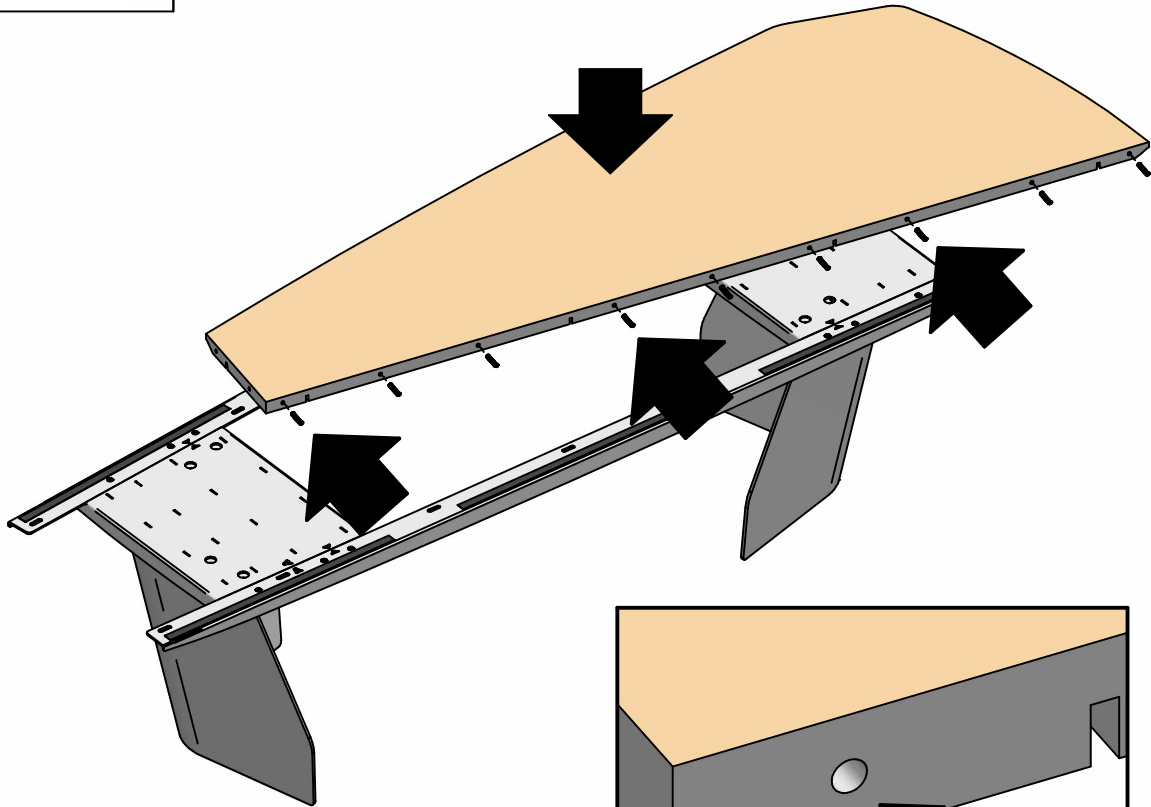
n° 09 $\varnothing 10 \times 50$.



n° 04 pz.

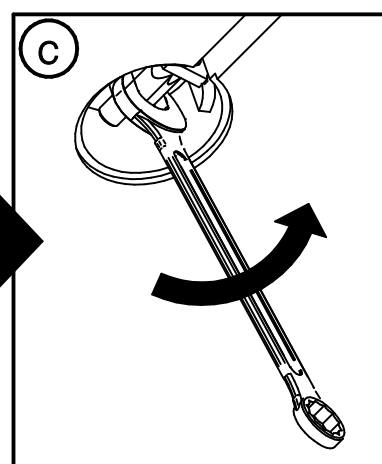
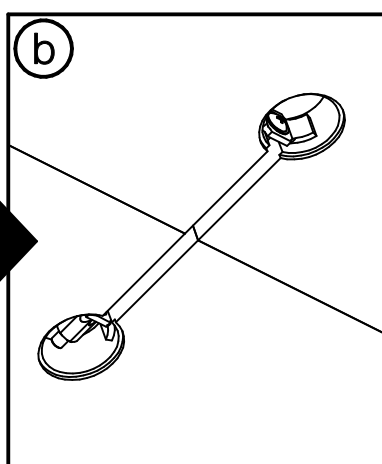
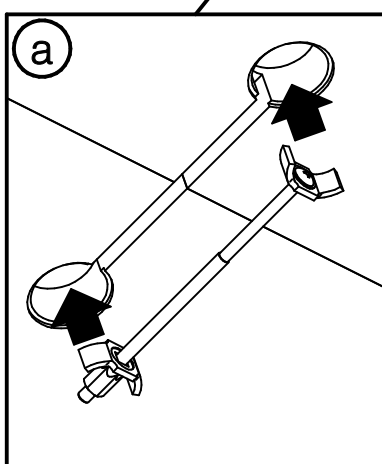
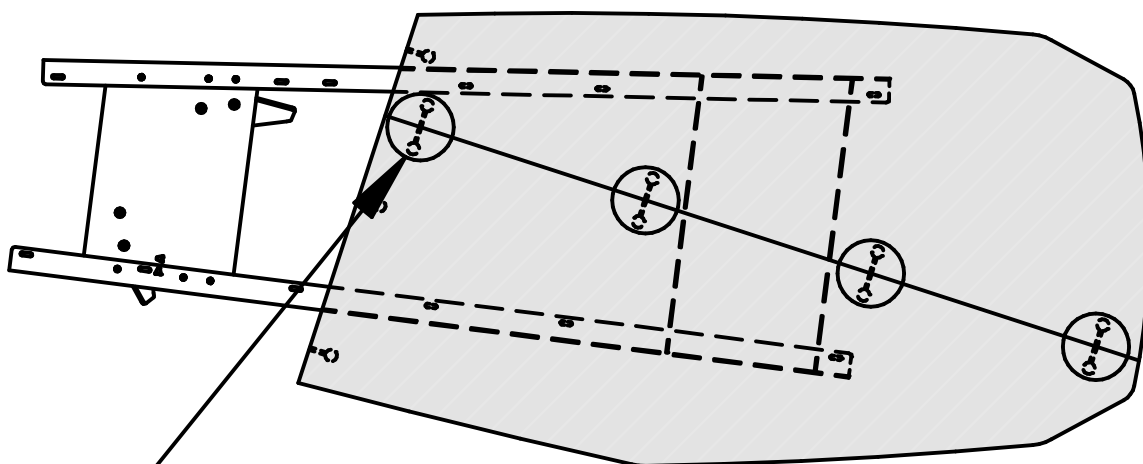
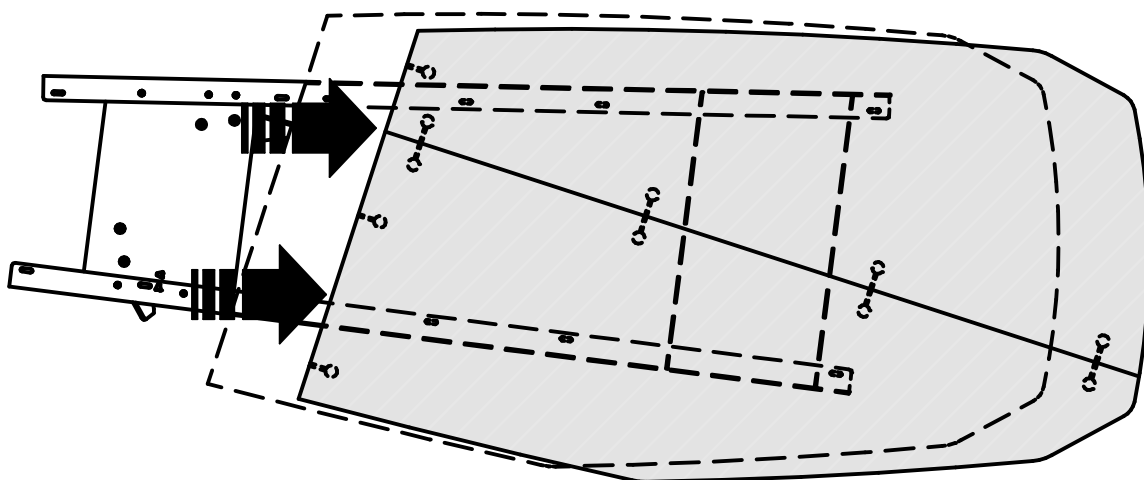
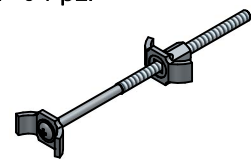

- IMPORTANTE: FISSARE IL DADO MODERATAMENTE!
- IMPORTANT : FIX THE NUT CAREFULLY!
- ACHTUNG: MAESSIG DIE SCHRAUBENMUTTER!
- IMPORTANT: FIXER L'ÉCROU MODÉRÉMENT!
- ¡IMPORTANTE: FIJAR LA TUERCA CON MODERACIÓN!

n° 06 ø10x50.

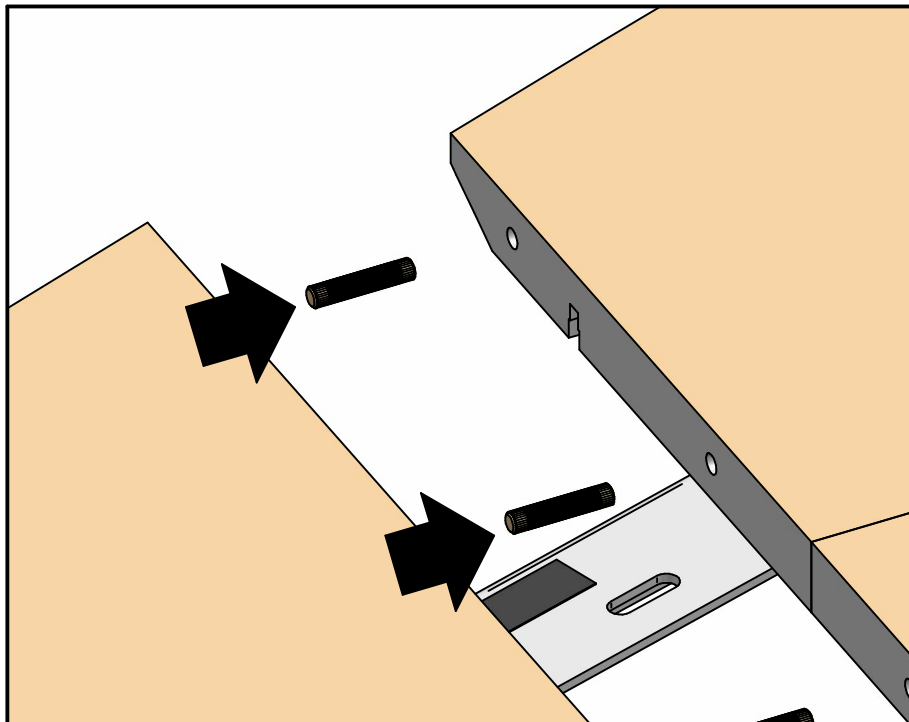
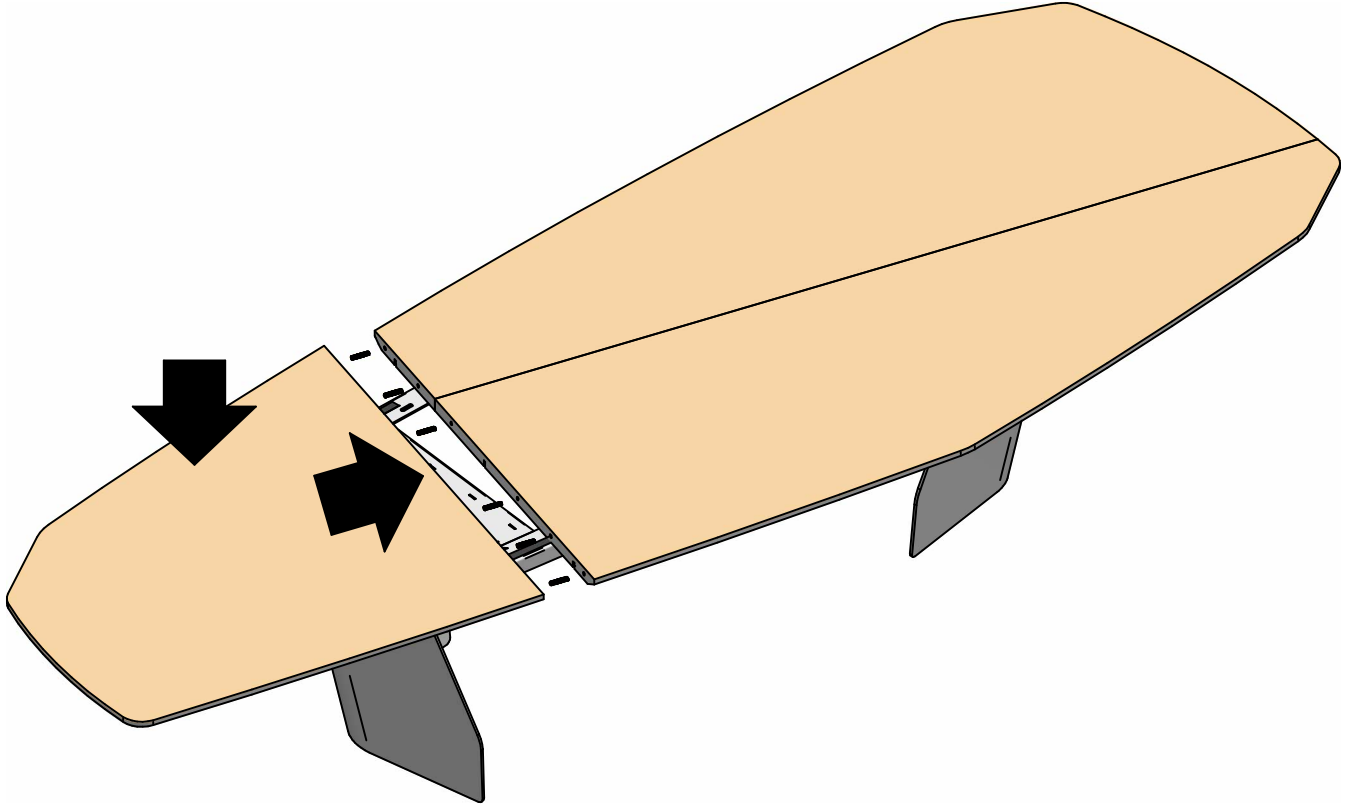
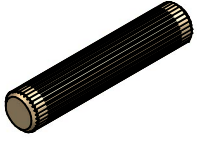



n° 03 pz.

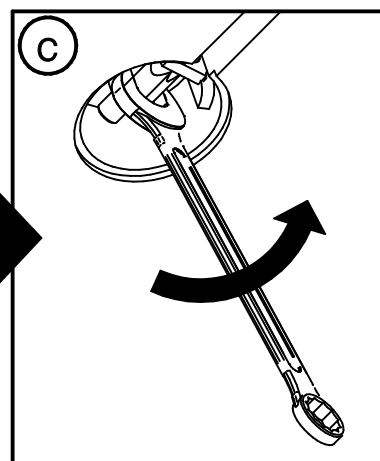
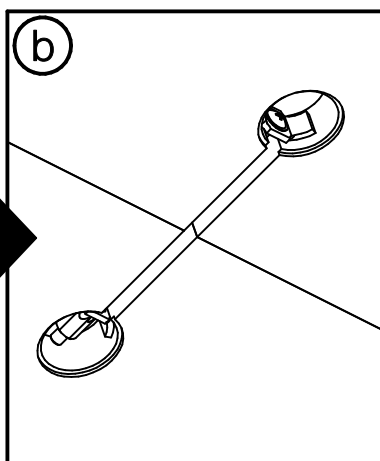
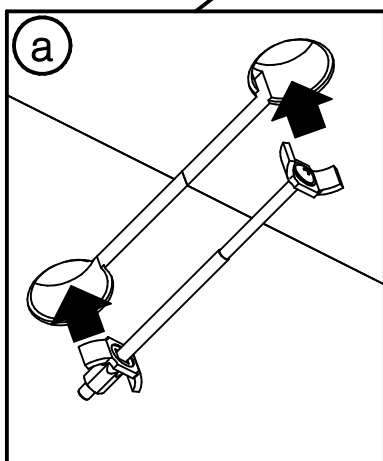
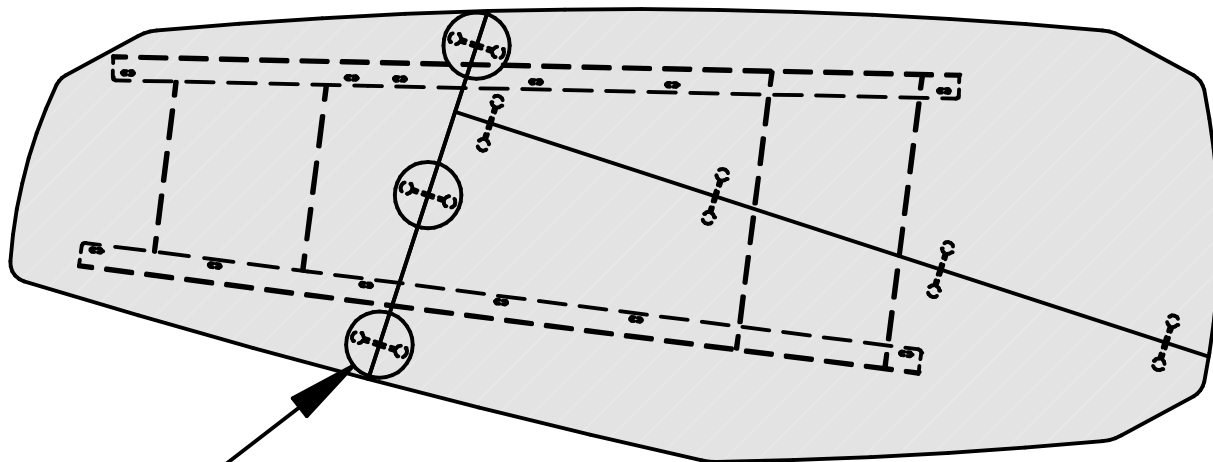
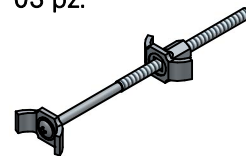

- IMPORTANTE: FISSARE IL DADO MODERATAMENTE!
- IMPORTANT : FIX THE NUT CAREFULLY!
- ACHTUNG: MAESSIG DIE SCHRAUBENMUTTER!
- IMPORTANT: FIXER L'ÉCROU MODÉRÉMENT!
- ¡IMPORTANTE: FIJAR LA TUERCA CON MODERACIÓN!

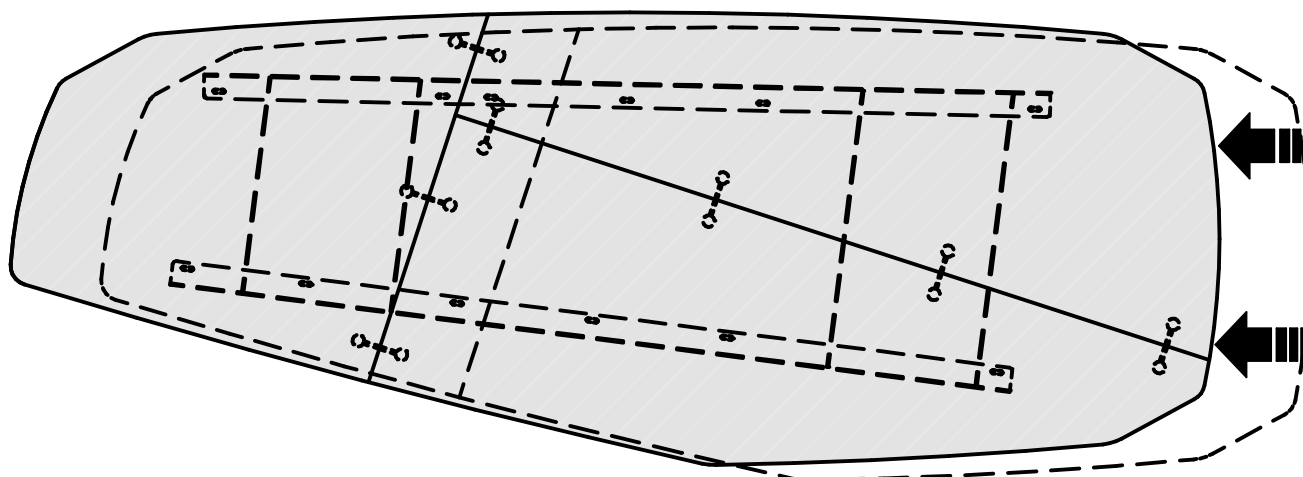

n° 12 TBCE M8x20 N.



n° 12 ø8x24 N.

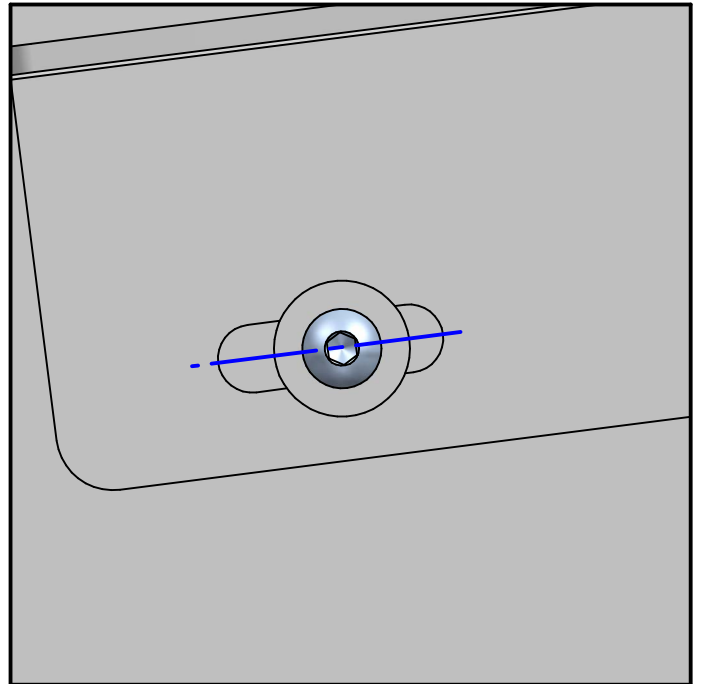
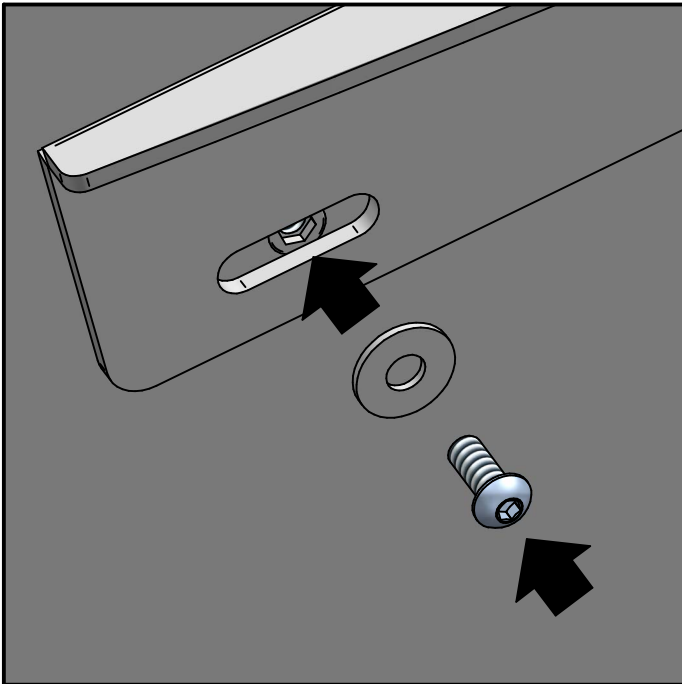
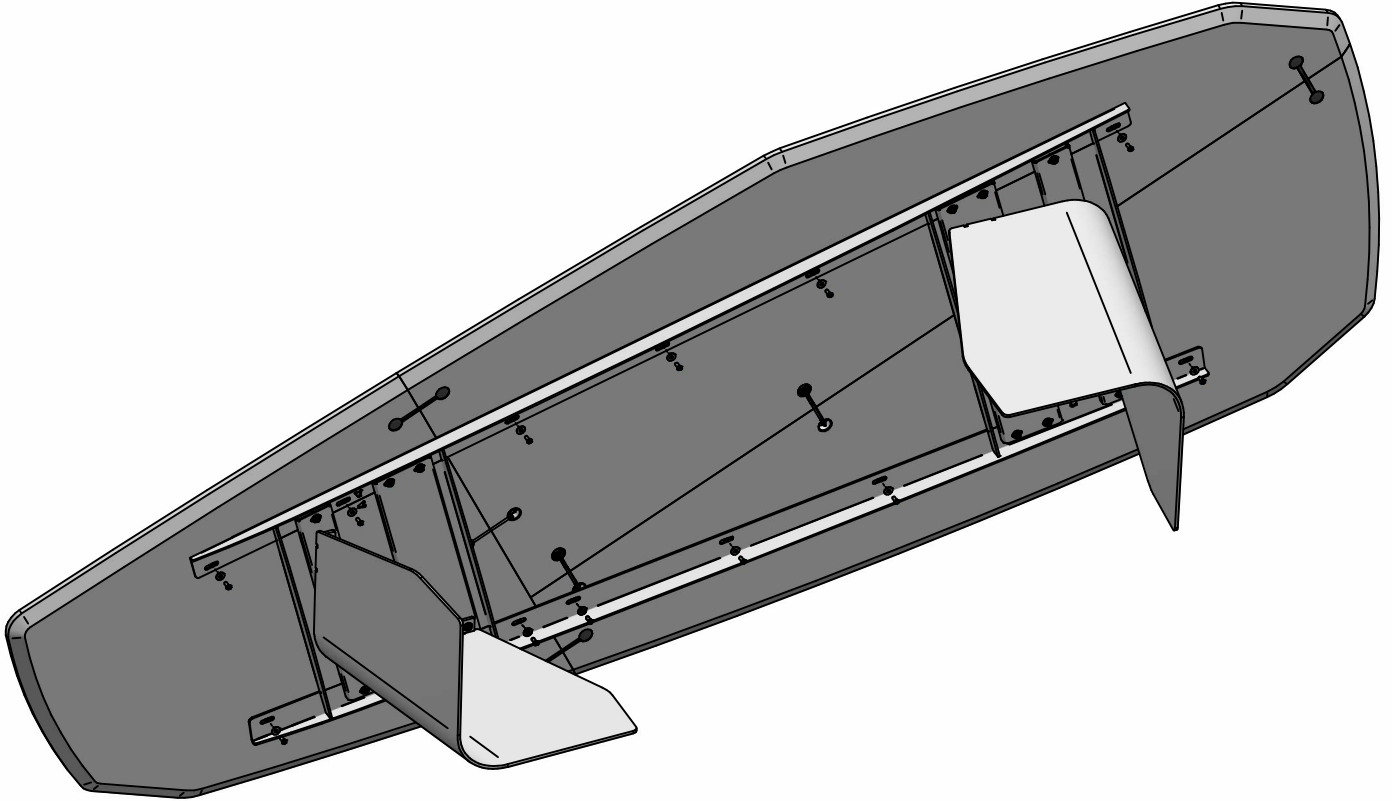
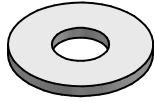

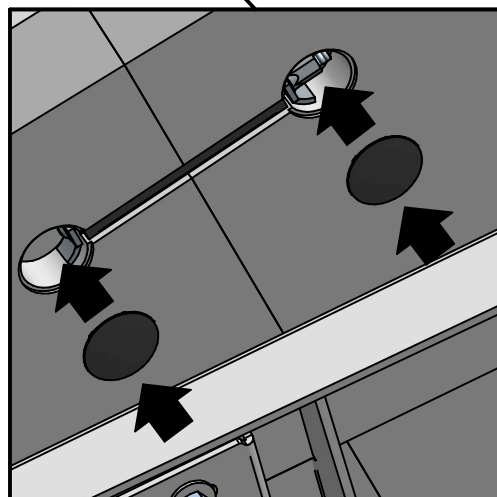
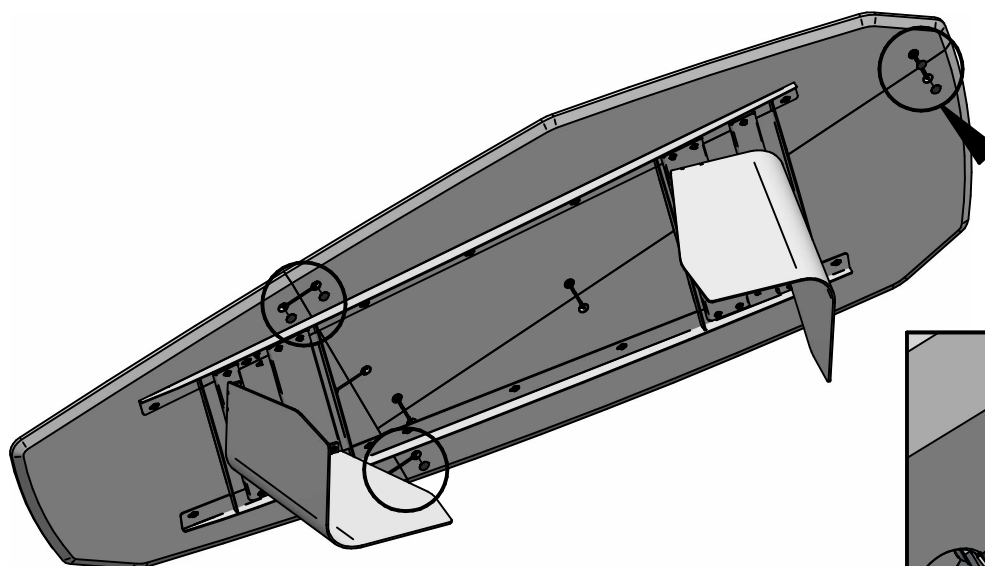
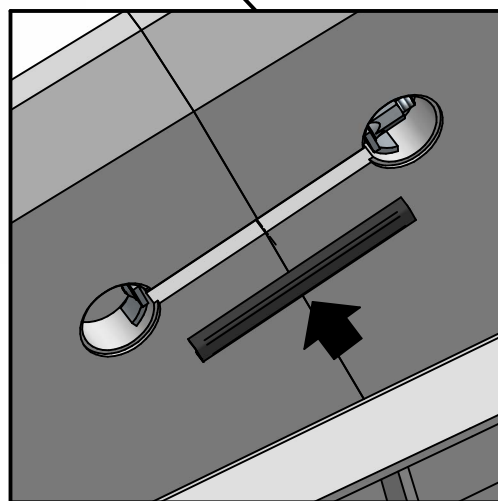
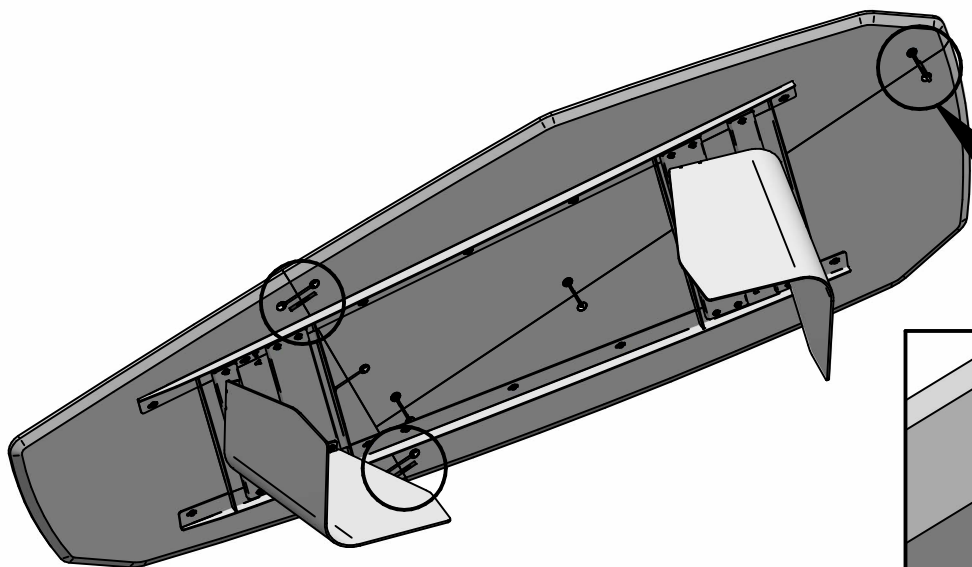
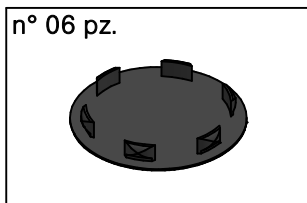
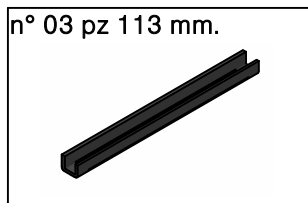

IT USO

Il prodotto è destinato per l'utilizzo all'interno delle abitazioni con l'uso per il quale è stato realizzato.

REALIZZAZIONE

Piccole irregolarità sulla base sono dovute alla lavorazione manuale del prodotto.

ATTENZIONE

Non spostare assolutamente mai il prodotto trascinandolo o sollevandolo prendendolo per il piano ma smontarlo e riposizionarlo dove voluto, assicurandosi di proteggere le parti che si potrebbero danneggiare.

SMALTIMENTO

Una volta dismesso, il prodotto od i suoi componenti non vanno dispersi nell'ambiente ma conferiti ai sistemi pubblici di smaltimento.

MANUTENZIONE

Non vanno assolutamente utilizzati strumenti metallici appuntiti o panni abrasivi per eliminare eventuali residui di sporco presenti sulla superficie del prodotto, in quanto possono danneggiare la superficie stessa. Non vanno assolutamente utilizzati detersivi che contengano cloro o a base di acido cloridrico, acido muriatico o prodotti anticalcare in quanto andrebbero ad alterare la brillantezza del prodotto.

MANUTENZIONE LEGNO

Il legno è un materiale vivo e come tale può avere mutamenti nel tempo di colore e di dimensione, gli oggetti che vengono appoggiati sul piano, devono essere spostati periodicamente poiché il legno è sensibile alla luce e si ossida, creando differenze di colore tra le parti esposte alla luce e quelle coperte. Per la normale pulizia utilizzare un panno morbido leggermente umido. Non usare detersivi abrasivi, solventi, ammoniaca, acetone o petrolio. Per la rimozione di macchie utilizzare una soluzione di acqua e sapone neutro, avendo l'accortezza di asciugare subito le superfici bagnate.

EN USE

The product is intended for an indoor use and may only be used for its intended purpose.

ACCOMPLISHMENT

Small irregularities on the base are due to manual processing.

WARNING

Do not move the product by dragging it or lifting it from the top, but reassemble it and place it in the new site, protecting the parts that could be damaged.

DISPOSAL

If your furniture is unusable or unrepairable, neither the product nor its components are to be dispersed in the environment, but rather consigned to public disposal systems.

MAINTENANCE

It is recommended not to use metal sharp tools or abrasive clothes to eliminate dirt from the surface, because they could damage the same. Do not absolutely use detergents containing chlorine, muriatic acid, hydrochloric acid or descale detergents which can damage the surface brilliance.

MAINTENANCE OF WOOD

Wood is a living material and therefore susceptible to slight colour and dimension changes. As the wood is sensitive to light and oxidizes, any item standing in the same place on the top for a long period of time can create colour differences between the covered and the exposed parts, so they should be moved periodically. Clean it with a slightly damp soft cloth. **DO NOT** use any chemicals or harsh detergents such as ammonia. To remove stains, wash the top with mild soap and water, and rinse. Dry the top thoroughly.

NUTZUNG

Das Produkt ist nur für den Innenbereich gedacht. Der Tisch wurde hergestellt, nur als Esstisch genutzt zu werden.

AUSFÜHRUNG

Kleine Unregelmäßigkeiten auf der Basis sind nicht zu vermeiden, da das Teil per Hand hergestellt wird.

WARTUNG

Niemals scharfe Werkzeuge aus Metall, spitzen Instrumente oder Schleifmittel für die Reinigung der Oberfläche verwenden. Diese Produkte können die Oberfläche beschädigen. Niemals Chemikalien mit chlorhaltigen Salzsäure, Salzsäure oder Kalk-Produkte für die Reinigung verwenden. Diese Produkte können der Glanz beschädigen.

PFLEGE DES HOLZES

Holz ist ein lebendes Material und kann sich in der Farbe und Grösse ändern. Objekte, die auf die Platte gestellt werden, müssen periodisch bewegt werden, da Holz lichtempfindlich ist und oxidiert und dadurch die Farbe ändert. Für die normale Reinigung genügt ein weiches, feuchtes Tuch. Bitte kein Scheuermittel, Lösungsmittel, Ammoniak, Aceton oder Öl verwenden. Zum Entfernen von Flecken milde Seife und Wasser benutzen, die nassen Oberflächen sofort abtrocknen.

ACHTUNG

Der Tisch absolut nie ziehen oder heben. Falls der Tisch soll bewegt werden, muss zerlegt werden und sorgfältig in der neue Stelle Positioniert. Die empfindliche teile sollen geschützt werden.

ENTSORGUNG

Nach der Aussonderung ist das Produkt und seine Bestandteile nicht selbständig im Freien zu entsorgen, sondern der städtischen Müllabfuhr zu übergeben.

WARTUNG

Niemals scharfe Werkzeuge aus Metall, spitzen Instrumente oder Schleifmittel für die Reinigung der Oberfläche verwenden. Diese Produkte können die Oberfläche beschädigen. Niemals Chemikalien mit chlorhaltigen Salzsäure, Salzsäure oder Kalk-Produkte für die Reinigung verwenden. Diese Produkte können der Glanz beschädigen.

UTILISATION

Le produit est destiné pour une utilisation à l'intérieur des habitations.

CONSTRUCTION

Les petites irrégularités sur la base sont dues à une fabrication manuelle.

MANUTENTION

Il ne faut pas absolument utiliser des outils pointus ou des chiffons abrasifs pour éliminer des possibles restes sur la surface du produit, parce qu'ils peuvent endommager la surface même. Ne pas utiliser des détergents contenant du chlore, acide chlorhydrique, acide muriatique ou produits anticalcaire qui peuvent altérer le brillant du produit.

ENTRETIEN BOIS

Le bois est une matière qui vit, et comme tel il peut avoir des changements de couleur, de dimension, les objets posé sur le plateau doivent être posé de façon intermittente car la sensibilité à la lumière peut créer des différences de ton entre les parties du plateau couverte ou non par les objets. Pour l'entretien, utilisez un chiffon doux et légèrement humide. Ne pas utiliser de revêtements abrasif, ammoniacque ou autre détergeant. Pour enlever les taches utiliser de l'eau et du savon neutre, en essuyant immédiatement les parties concernées.

ATTENTION

Ne pas absolument déplacer le produit en le trainant ou en le soulevant par le top, mais démontez-le et positionnez-le autre part, en s'assurant de protéger les parties qui pourraient s'endommager.

ECOULEMENT

Une fois disloqué, le produit ou ses composants ne doivent pas être dispersés dans la nature mais confiés aux décharges publiques.

MANUTENTION

Il ne faut pas absolument utiliser des outils pointus ou des chiffons abrasifs pour éliminer des possibles restes sur la surface du produit, parce qu'ils peuvent endommager la surface même. Ne pas utiliser des détergents contenant du chlore, acide chlorhydrique, acide muriatique ou produits anticalcaire qui peuvent altérer le brillant du produit.

ES **USO**

El producto está destinado para su uso dentro del hogar, a los fines por los cuales fue creado.

CONSTRUCCIÓN

Pequeñas irregularidades en la base están causadas por la producción manual.

MANTENIMIENTO

No utilizar en cualquier forma instrumentos de metal afilados o telas abrasivas para eliminar cualquier resto de suciedad en la superficie del producto, ya que pueden dañar la superficie misma. No utilizar en cualquier forma limpiadores a base de cloro o que contienen ácido clorhídrico, ácido muriático o productos anticalcáreos ya que pueden alterar el brillo del producto.

ATENCIÓN

No muevan absolutamente nunca el producto arrastrándolo o mediante el levantamiento del plano, sino desmontarlo y llevarlo a donde querían, asegurándose de proteger las partes que pueden dañarse.

ELIMINACIÓN DE DESECHOS

Una vez desechado, el producto o sus componentes no se tienen que abandonar en el entorno sino entregar al sistema público de recogida de basuras.

MANTENIMIENTO

No utilizar en cualquier forma instrumentos de metal afilados o telas abrasivas para eliminar cualquier resto de suciedad en la superficie del producto, ya que pueden dañar la superficie misma. No utilizar en cualquier forma limpiadores a base de cloro o que contienen ácido clorhídrico, ácido muriático o productos anticalcáreos ya que pueden alterar el brillo del producto.

MANTENIMIENTO MADERA

La madera es un material vivo y, como tal, puede tener cambios con el tiempo de color y tamaño, los objetos que se colocan en el sobre, se deben mover periódicamente ya que la madera es sensible a la luz y se oxida, creando diferencias de color entre las piezas expuestas a la luz y las cubiertas. Para la limpieza normal, use un paño suave ligeramente humedecido. No use limpiadores abrasivos, disolventes, amoníaco, acetona y aceite. Para quitar las manchas utilizar una solución de jabón suave y agua, asegurándose de secar las superficies mojadas inmediatamente.

RU **ИСПОЛЬЗОВАНИЕ**

Изделие предназначено для использования внутри помещения.

РЕАЛИЗАЦИЯ

Небольшие неровности на основе связаны с обработкой изделия вручную.

ВНИМАНИЕ

При перемещении изделия, никогда не перетаскивайте и не поднимайте его, взяв за верх, для начала разберите его и переставьте в нужное место, позаботившись о защите частей, которые могут быть повреждены.

УТИЛИЗАЦИЯ

После утилизации, продукт и его компоненты не должны разлагаться в окружающей среде, а должны быть переданы в специализированные места утилизации.

УХОД

Не используйте острые металлические инструменты или абразивные губки для удаления грязи, так как они могут повредить поверхности. Ни в коем случае не используйте моющие средства, содержащие хлор, соляную кислоту или средства от известкового налета, поскольку они могут повлиять на блеск предмета.

УХОД ЗА ДЕРЕВОМ

Дерево - это живой материал, и поэтому оно может со временем меняться в цвете и размере. Предметы, которые размещаются на столешнице, необходимо периодически перемещать, поскольку дерево чувствительно к свету и окисляется, создавая цветовые различия между участками, подвергнутыми воздействию света и покрытыми участками. Для обычной чистки используйте мягкую, слегка влажную тряпку. Не используйте абразивные чистящие средства, растворители, аммиак, ацетон или нефть. Чтобы удалить пятна, используйте раствор из воды и нейтрального мыла, сразу просушив влажные поверхности.

使用:

此产品仅限于室内使用，也只能按其用途使用。

处理方法:

如果家具不能使用或是不能修复，不要把产品及其部件散步在外面，应将其交由公共处置系统。保养

不建议

使用锋利的金属工具或磨料织物去除表面上的污垢，因为它们可能会损害产品。请勿使用含有氯林，盐酸，氢氟酸的洗涤剂或浓缩洗涤剂清理产品，因为它们会破坏产品表面的光泽。

木质保养

木头属于天然材料，颜色和尺寸易因环境发生变化。木材对光线和氧气较为敏感，长时间在木面上一个位置长时间放置一件东西，会使遮盖部分和外露部分形成颜色差异，所以摆放的物品应该定期移动。

用柔

软的湿布进行擦拭，请勿使用任何化学制剂或刺激性强的洗涤剂，比如含氨的产品。如果要去除污点，可以用温和的肥皂和水清洗，然后冲洗掉，最后使木面完全干燥即可。

**cattelan
italia**

CATTELAN ITALIA SPA

Via Pilastri, 19

36010 Carré (VI), Italy

Ph. +39 0445 318711

info@cattelanitalia.com

www.cattelanitalia.com

